

# Airco



F.W. WEBB COMPANY

## Premium Oil Furnaces

Keeping Families Comfortable for more than 60 years



### FEATURING

- ✓ Optional ECM Motor
- ✓ AFUE Up to 88%
- ✓ Air Conditioning Ready
- ✓ High Grade Stainless Steel Combustion Chamber

[aircofurnaces.com](http://aircofurnaces.com)

# Airco Provides Premium Solutions In Oil Heating For Your Family.



## Why Choose Airco?

You want your home to be comfortable, but you also need to be mindful of annual fuel costs, maintenance and dependability. Airco oil furnaces have been reliably heating homes for generations. If you want the most out of your next heating system, Airco has the optimal oil furnace solution for you.

Our innovative products feature ENERGY STAR® models that can achieve efficiencies up to 88% AFUE\*. Installing a higher efficiency Airco furnace provides more heat for every dollar spent and may also qualify for energy-efficiency rebates or incentives.

## COMPARATIVE ANNUAL HEATING OIL CONSUMPTION CHART

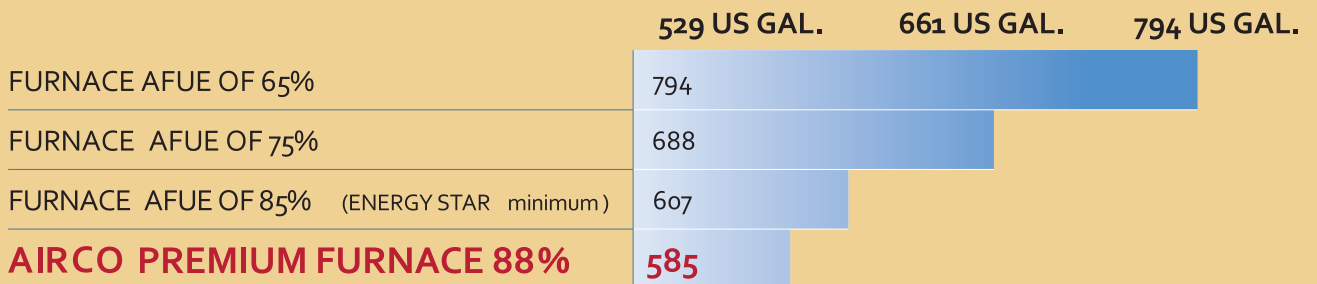

Example of a yearly heating oil consumption (US gallons)

\* Annual Fuel Utilization Efficiency



## Quality and care goes into every Airco furnace

We stand behind every Airco product we engineer and build with a strong warranty.

Limited Lifetime Heat Exchanger Warranty and a 5 year parts warranty.



# Uncompromised Comfort

## Optimal Efficiency



### 1 ROBUST AND DURABLE COMBUSTION CHAMBER

- 100% premium stainless steel construction
- Heats up more quickly
- Helps in maintaining a more even temperature in the home
- Brings additional heating savings compared to conventional appliances
- More durable
- Easier to service

### 2 SECONDARY TUBULAR HEAT EXCHANGERS

- 100% welded one-piece heat exchanger, no bolts and fasteners
- Premium steel
- Provided with stainless steel baffles to maximize heat transfer from the heat exchanger
- The tubular design of the secondary heat exchanger provides maximum thermal exchange
- Due to low air restriction these appliances are compatible with today's high efficiency heat pumps or air conditioning systems

### 3 BLOWER OPTIONS

- Comes with standard efficiency PSC blower motors or with high efficiency ECM blower motors (the ECM type motor provides additional operating utility savings compared to conventional motors)
- Easy-to-remove system for service and maintenance

### 4 SAFE AND EASY-TO-USE ELECTRONIC CONTROL

- Controls the burner operation and speeds of the fan motor
- Provides on-board connections for optional electronic air cleaner and humidifier
- On-board connections for A/C systems
- Continuous low-speed fan switch
- Compatible with heat pumps operating controls

### 5 HIGH-EFFICIENCY OIL BURNERS

- Offered with high static pressure burners that offer a better control of the combustion excess air allowing for a cleaner and more efficient combustion
- Electronic safety controls
- High-power electric ignition

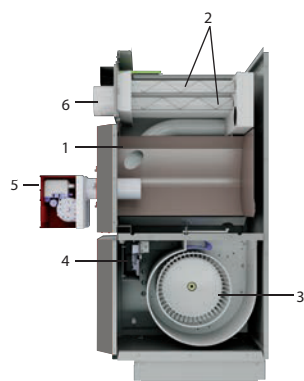

KHM

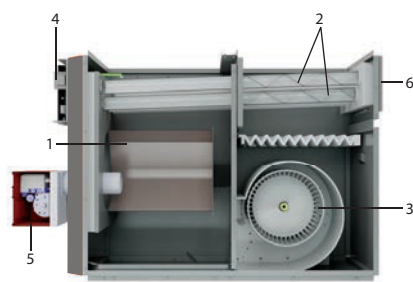

KLR

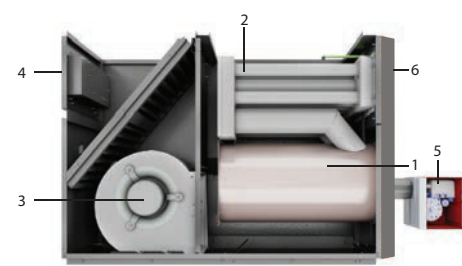

KLF

### 6 VENTING

- KLR rear breech, KLF/KHM front breech

## Our Most Versatile Furnace Series!

### The Multi-Position KHM Highboy Furnace

Can be installed anywhere due to its small footprint. One unit - 4 installation options:

- Upflow
- Downflow
- Horizontal right
- Horizontal left

The heat exchanger offers the highest heating efficiency for a standard highboy furnace.



KHM-100



KHM	100	200
Btu/h Input	77,000 - 161,000	
Efficiency	Up to 87.5%	
Flue Location	Front	
Height	46 1/4"	49 7/8"
Supply Opening	20" x 20"	24" x 20"
Return Opening	18" x 18"	23" x 18"
Heat Exchanger	Welded Stainless Steel	

#### Features

##### Chimney Vent Burner Options

- Beckett AF
- Riello 40F3 / 40F5
- Carlin EZ

##### Direct Vent Burner Option

- Riello 40BF3 / 40BF5

##### Blower Motor Options

- ECM Multi-Speed High Efficiency
- PSC Direct Drive

##### Other

- Filter:  
KHM-100 (1) 20" x 20" x 2"  
KHM-200 (1) 25" x 20" x 2"

- Barometric damper

- A/C ready

##### ENERGY STAR® Certified at all firing rates

- Requires ECM Blower Motor

# Lowboy Series KLR / KLF

## Rear Flue and Front Flue



KLR-100



KLF-100



KLR	100	200
Btu/h Input	77,000 - 161,000	
Efficiency	Up to 88.0% AFUE	
Flue Location	Rear	
Height	33"	33"
Supply Opening	20" x 20"	20" x 24"
Return Opening	20" x 20"	20" x 22"
Heat Exchanger	Welded Stainless Steel	

KLF	100	200
Btu/h Input	77,000 - 154,000	
Efficiency	Up to 87.5% AFUE	
Flue Location	Front	
Height	29 3/8"	35 1/8"
Supply Opening	18" x 21 3/4"	20" x 24"
Return Opening	18" x 20 3/4"	20" x 20"
Heat Exchanger	Welded Stainless Steel	

### Features

#### Chimney Vent Burner Options

- Beckett AF
- Riello 40F3 / 40F5
- Carlin EZ

#### Direct Vent Burner Option

- Riello 40BF3 / 40BF5

#### Blower Motor Options

- ECM Multi-Speed High Efficiency
- PSC Direct Drive

#### Other

- Front access to heat exchanger, easy service
- Filter:

KLR-100 20" x 20" x 2"

KLR-200 15" x 20" & 20" x 20" x 2"

KLF-100 20" x 20" x 2"

KLF-200 (2) 15" x 20" x 2"

- Barometric damper
- A/C ready

#### ENERGY STAR® Certified at all firing rates

- Requires ECM Blower Motor

# Flexible Burner Options - KHM, KLR, KLF

Take advantage of today's modern burner technology. Choose from Beckett, Carlin or Riello burners. Unit is shipped without the burner installed to aid in ease of installation.



Beckett Burner



Carlin Burner



Riello Burner

## Direct Vent Materials

Direct Venting (DV) is available on the KHM, KLR & KLF models using only a Riello BF burner.

- Replaces conventional chimneys
- 100% stainless steel coaxial terminal
- Sealed combustion using balanced flue burners
- Comes standard with an auto-reset pressure switch protection device in case of flue or air intake blockage
- Brings outside combustion air, ideal for air-tight homes
- Stainless steel flue pipe available in 10, 15 or 20 feet lengths

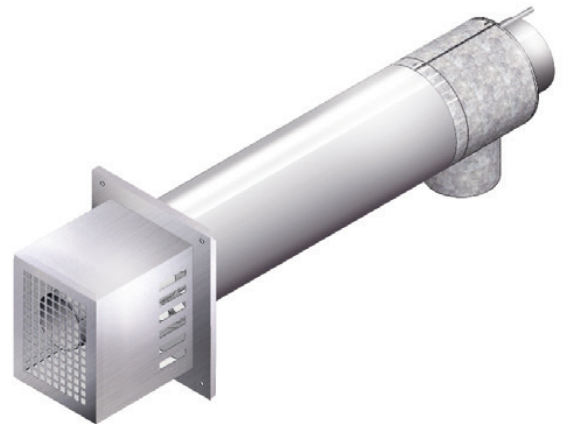

The following items are required for a complete DV Installation:

- Riello BF Burner In A Box
- DV Concentric Termination Kit (3DV-00-TERM-20)
- DV Vent Kit - Choose from 10', 15' or 20'
- Optional DV 4", 90° Stainless Elbow

**DV Vent Kits include:** 5" Stainless Steel Elbow, Appliance Adapter, Insulated Exhaust Pipe, Termination Adapter, Fresh Air Pipe and Riello Burner Fresh Air Pipe Adapter.



# Specifications - KHM, KLR, KLF

Furnace Model	KHM-100	KHM-200	KLR-100	KLR-200	KLF-100	KLF-200
Firing Rate	0.55   0.65   0.75	0.85   1.00   1.15	0.55   0.65   0.75	0.85   1.00   1.15	0.55   0.65   0.75	0.85   1.00   1.10
Input Capacity MBH	77   91   105	119   147   161	77   91   105	119   147   161	77   91   105	119   140   154
Output Capacity MBH	66   79   91	102   126   139	66   79   91	102   126   139	66   79   91	102   119   132
AFUE %	86.0 to 86.8	86.4 to 87.5	86.2 to 87.1	86.5 to 87.8	86.2 to 87.1	86.3 to 88.6
ENERGY STAR® (ECM Motor Only*)	Yes	Yes	Yes	Yes	Yes	Yes
A/C Ready electronic operating control	Yes	Yes	Yes	Yes	Yes	Yes
Chimney Vent	Yes	Yes	Yes	Yes	Yes	Yes
Direct Vent (Riello Burner Only)	Optional	Optional	Optional	Optional	Optional	Optional
PSC Blower Motor hp Number Speeds	1/2 hp 4	3/4 hp 4	1/2 hp 4	3/4 hp 4	1/2 hp 4	3/4 hp 4
CFM at 0.50" wc (ext. static pressure)	1275	2030	1275	2030	1275	2030
ECM blower motor* Number Speeds	1/2 hp 5	3/4 hp 5	1/2 hp 5	3/4 hp 5	1/2 hp 5	3/4 hp 5
CFM at 0.50" wc (ext. static pressure)	1230	1910	1230	1910	1230	1910
Height	46 1/4"	49 7/8"	33"	33"	29 3/8"	35 1/8"
Width	21 7/16"	21 7/16"	21 1/2"	21 1/2"	21 1/2"	21 1/2"
Depth	26"	30"	49 1/8"	55 1/8"	53 5/8"	52 5/8"
Weight	204 lbs.	240 lbs.	204 lbs.	240 lbs.	210 lbs.	240 lbs.
Flue Diameter	5"	5"	5"	5"	5"	5"
Supply Plenum Size	20" x 20"	24" x 20"	20" x 20"	20" x 24"	18" x 21 3/4"	20" x 24"
Return Plenum Size	18" x 18"	23" x 18"	20" x 20"	22" x 22"	18" x 20 3/4"	20" x 20"

\*Certification to ENERGY STAR® at every firing rate with ECM motor only.

Specifications subject to change without notice.



# Airco®

## Oil Furnaces



F.W. WEBB COMPANY

ECR International takes pride in offering a full line of heating and cooling appliances including the Airco brand of oil furnaces. The full line of quality Airco oil furnaces offers brand recognition, application versatility and a wide range of energy-efficient models that are easy to install and maintain.

Airco products have been manufactured for over 60 years, and ECR International is committed to providing you with the best heating products and support to allow you to service your customers better. Browse our products online at [www.olsenhvac.com](http://www.olsenhvac.com) to learn more about how Airco can meet your heating needs.

**F.W. Webb Company**  
**160 Middlesex Turnpike**  
**Bedford, MA 01730**  
**781-272-6600**



**ECR international**

2201 Dwyer Avenue, Utica, NY 13501  
Tel. 800 253 7900  
[www.ecrinternational.com](http://www.ecrinternational.com)

All specifications subject to change without notice.  
©2023 ECR International, Inc.  
PN 240013764A REV. [04/13/2023]